

BACK VIEW (without closing plates)

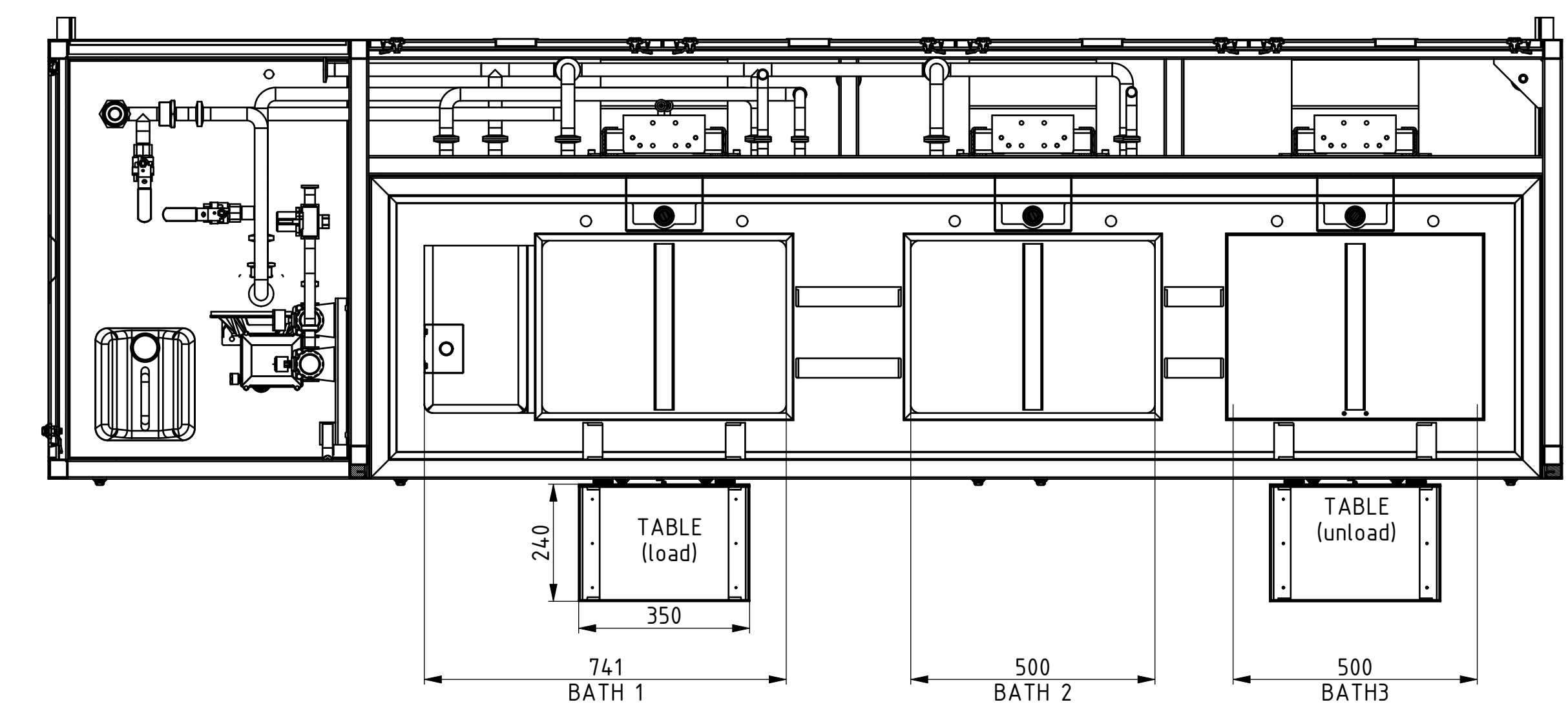

1:15

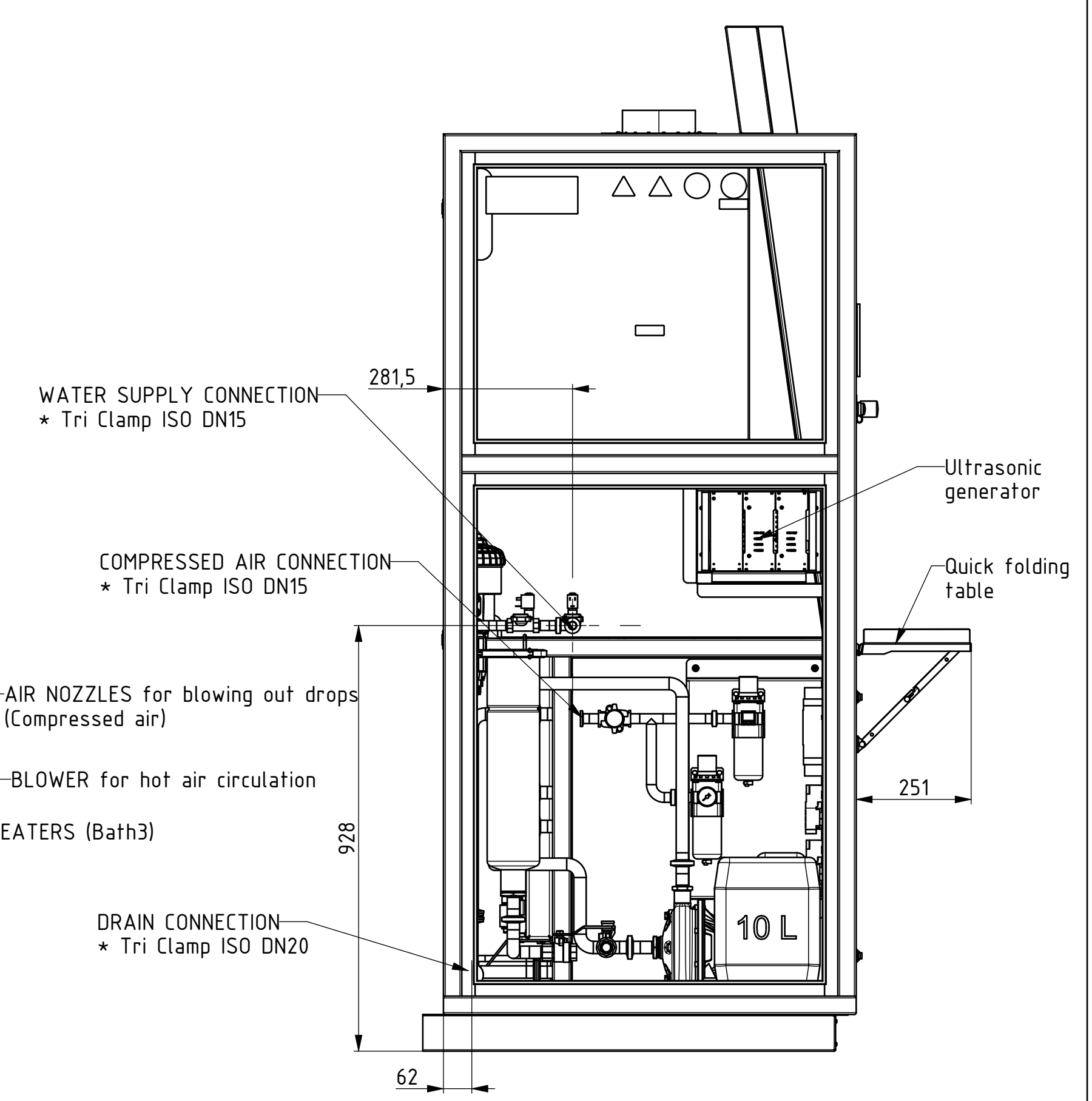
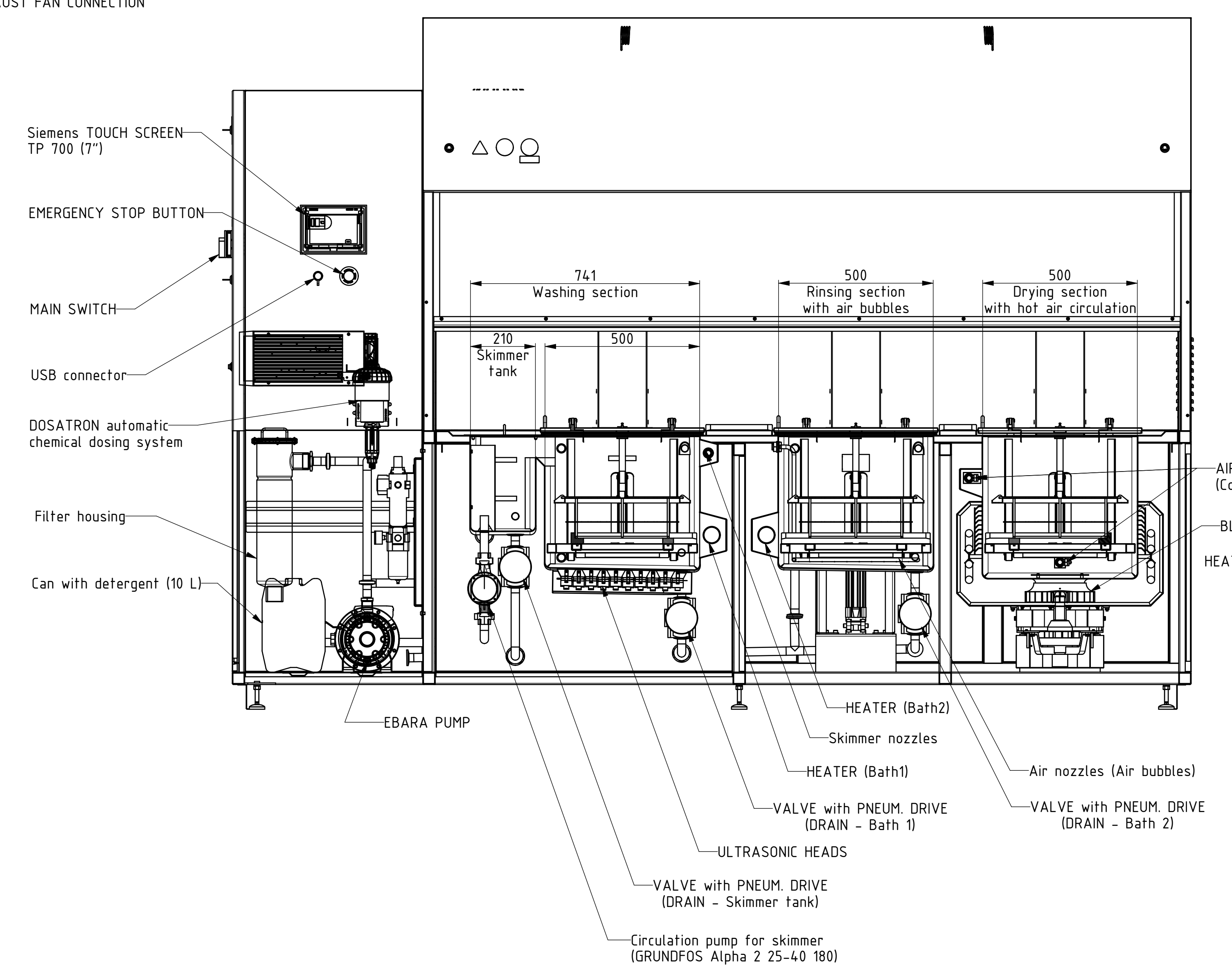
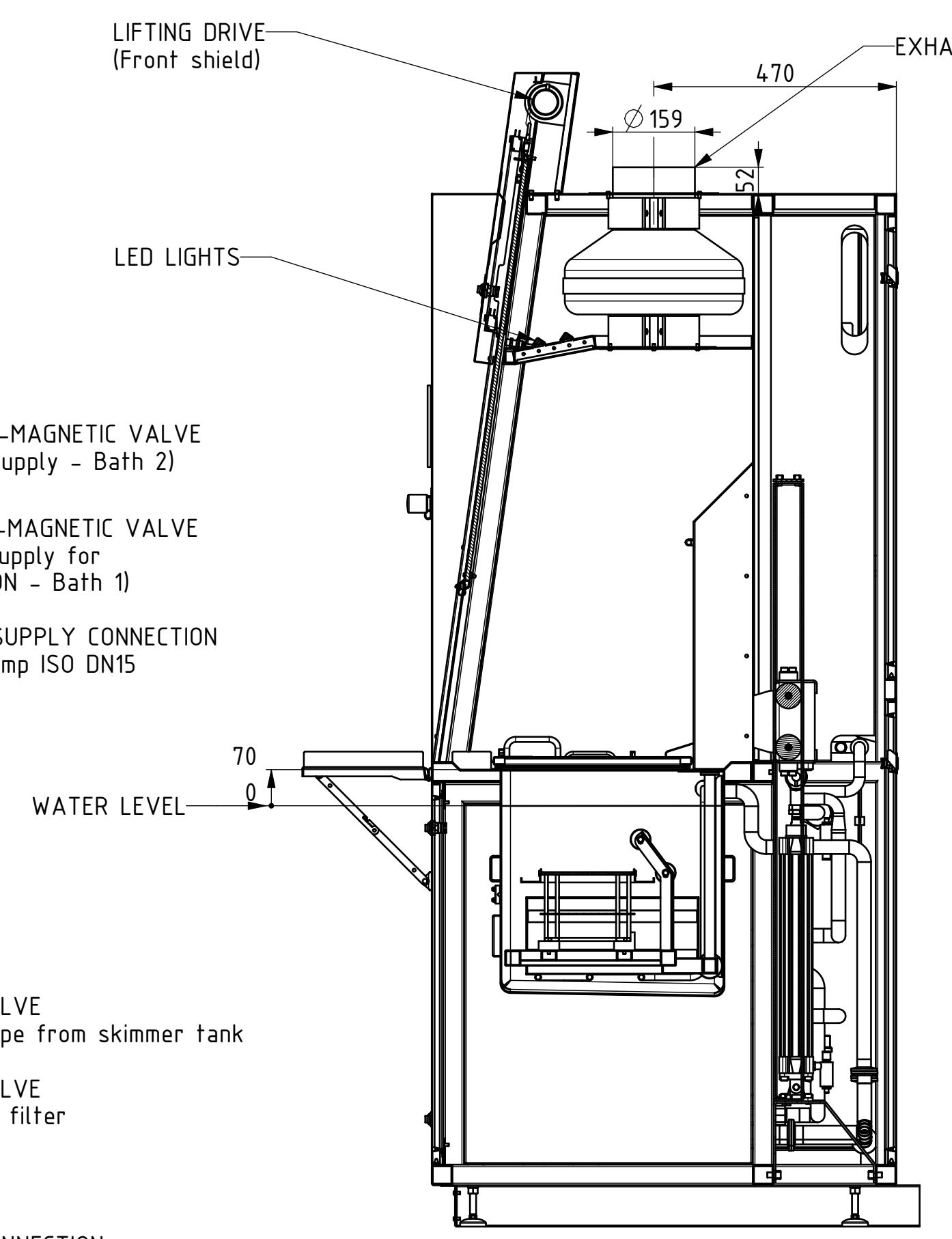
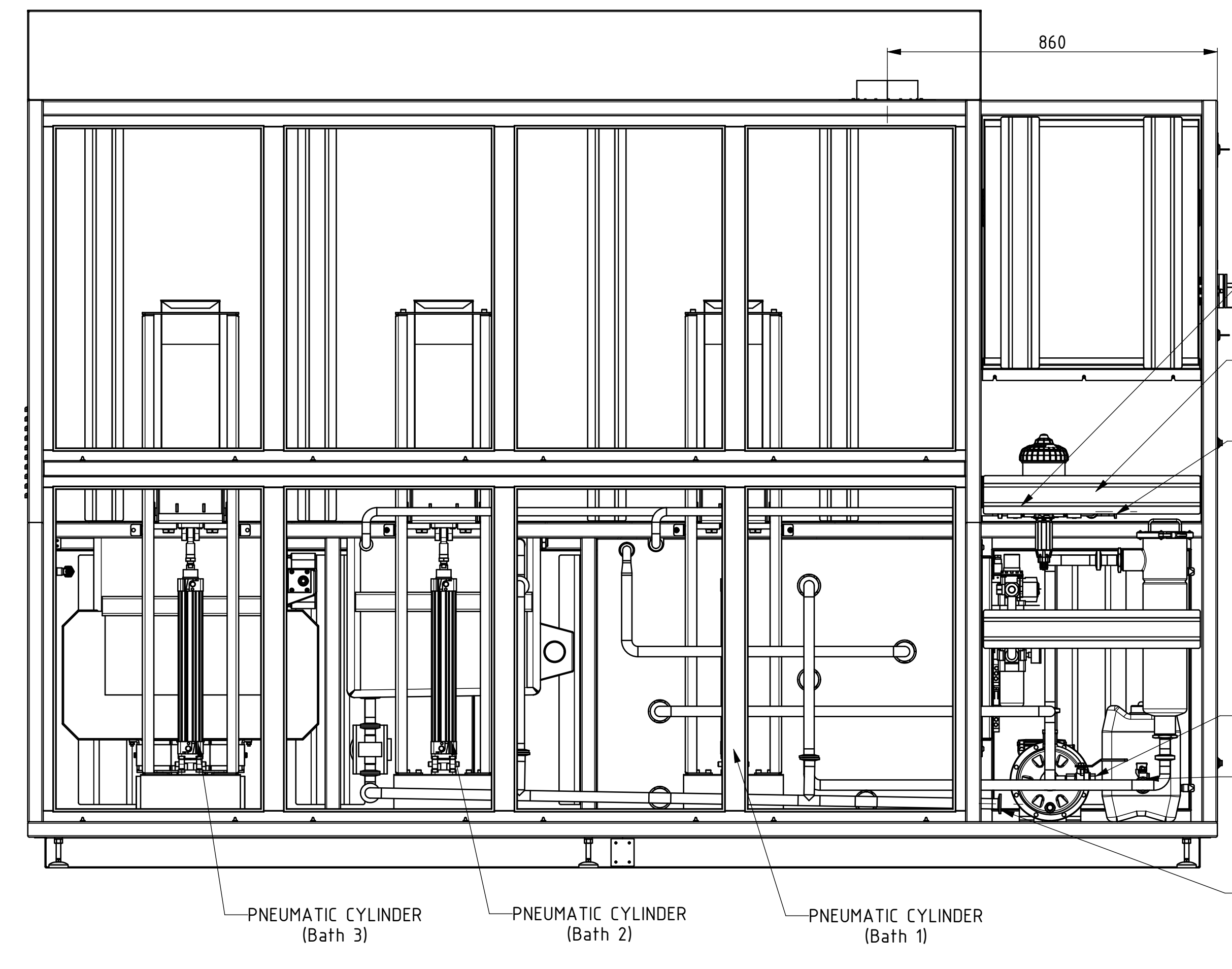
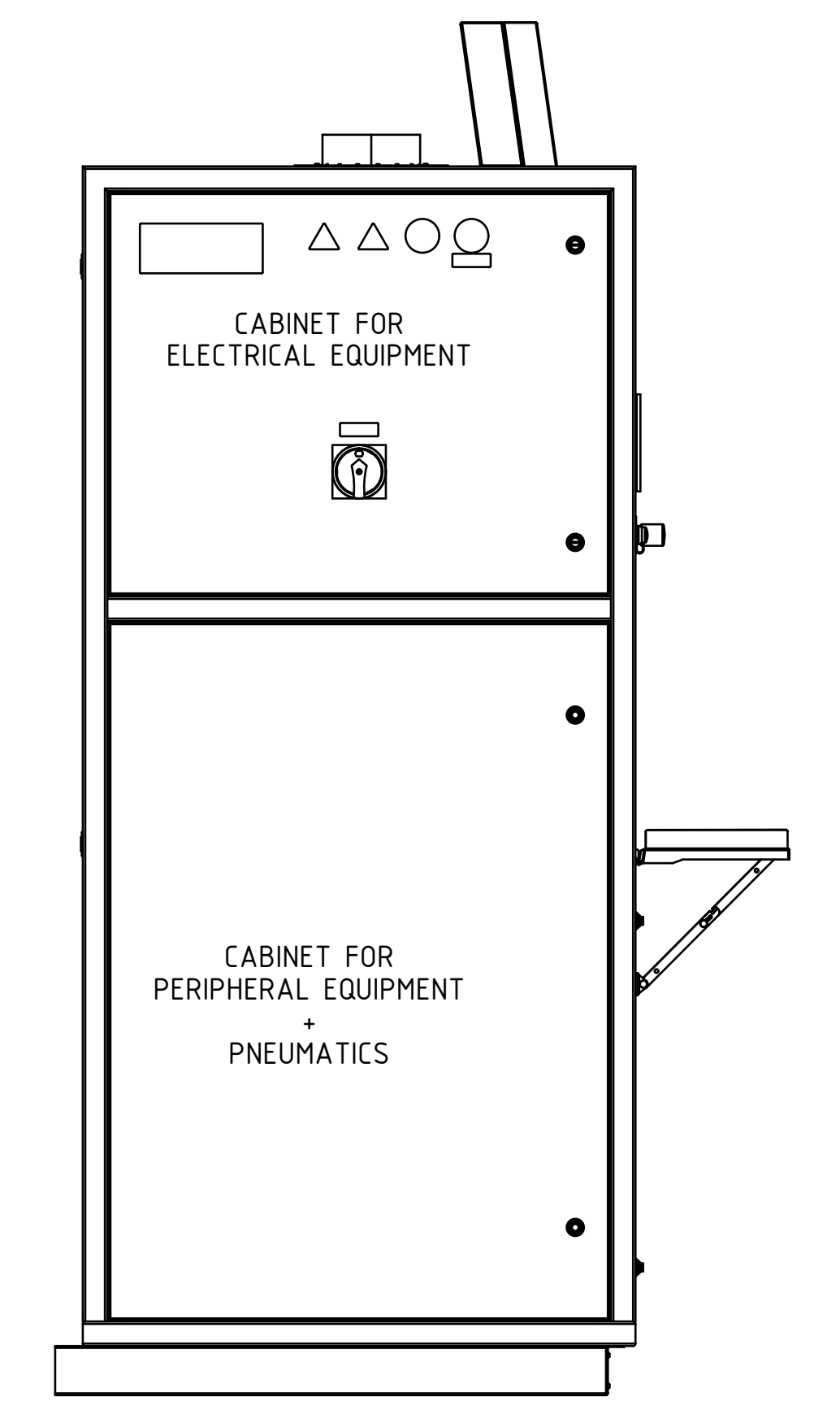
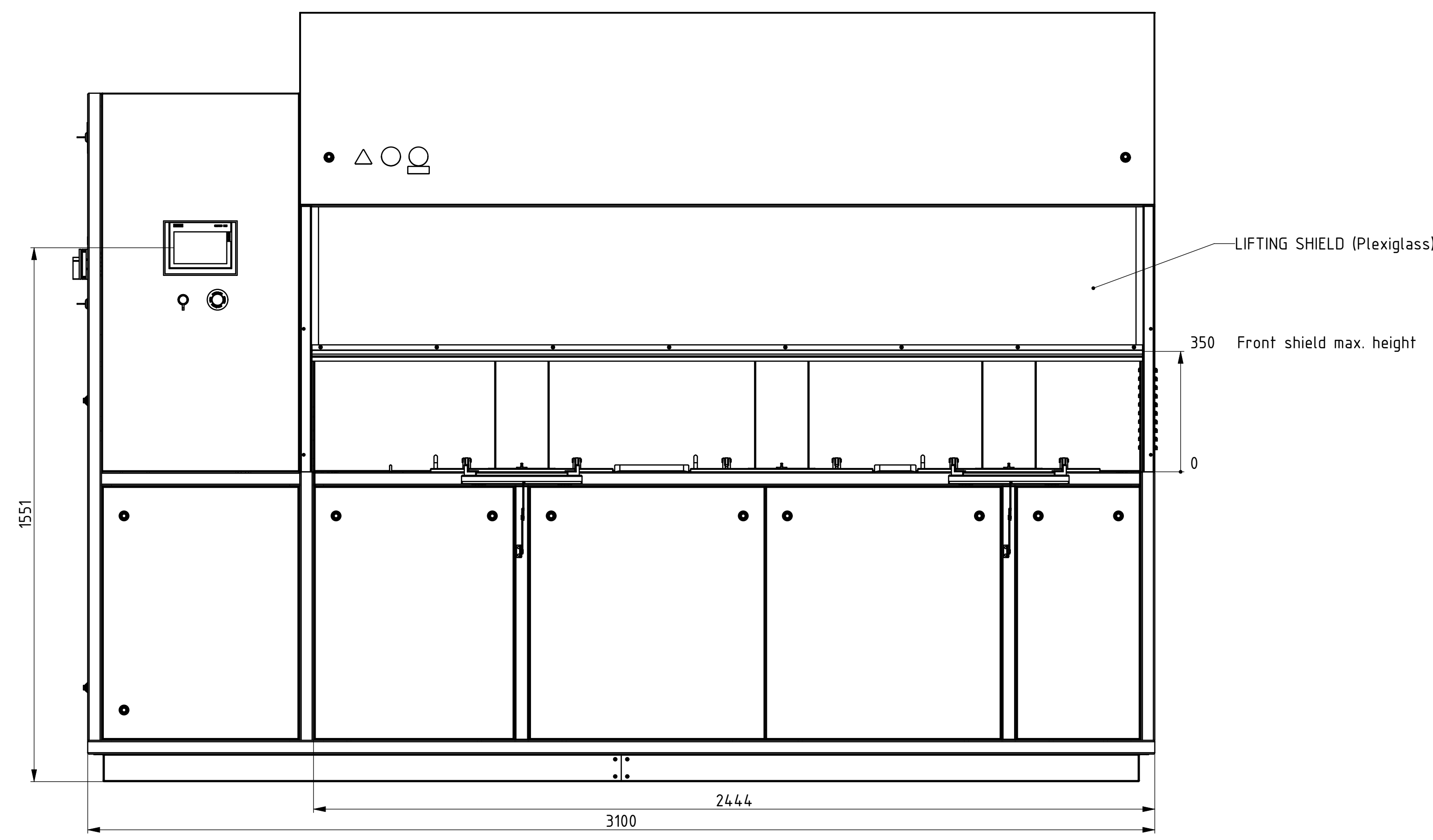
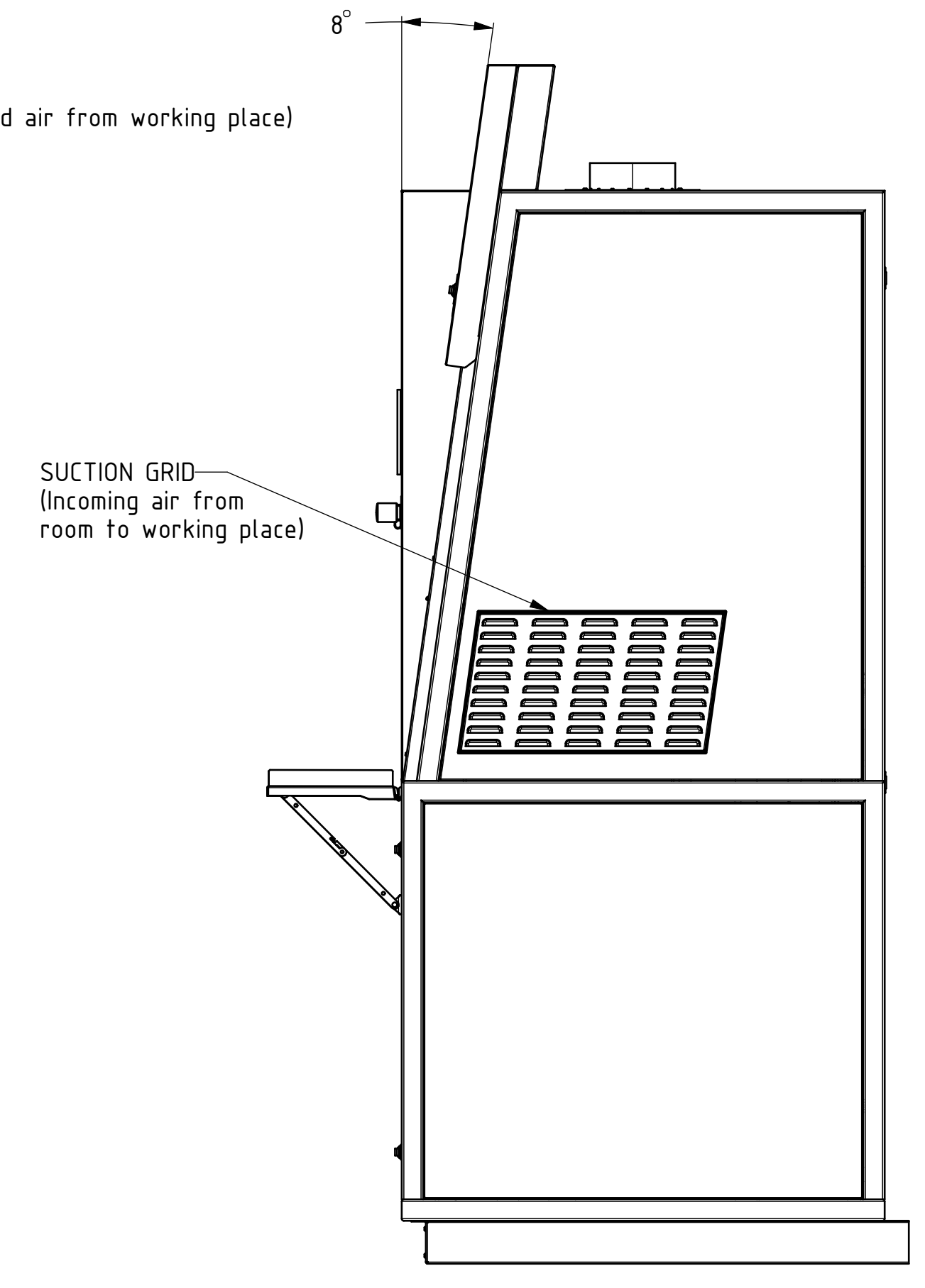
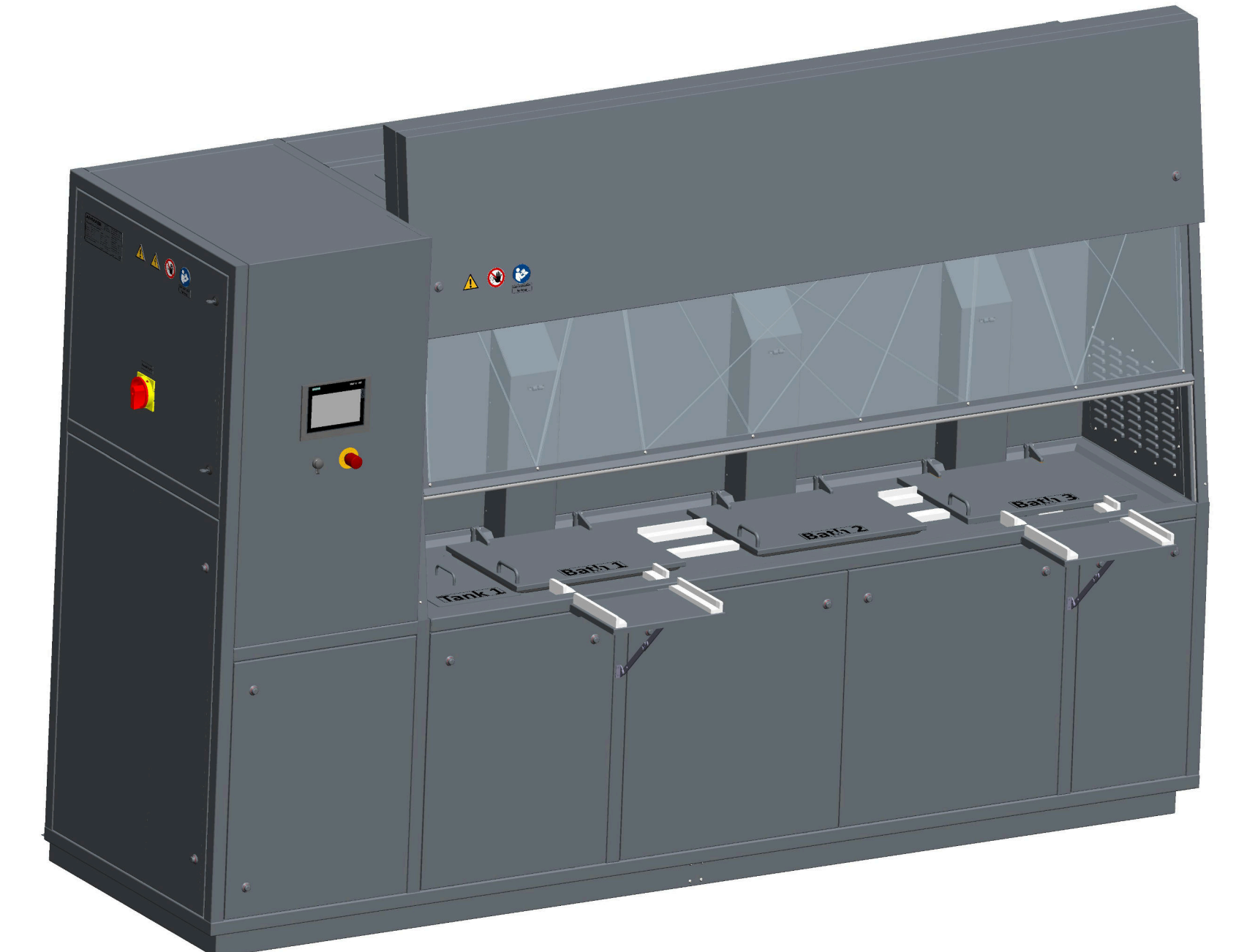

1:15

- BATH1 - Washing section:**
 - * ultrasonic transducers 1,5 kW
 - * heaters 3 kW
 - * level sensor
 - * overflow drain
 - * overflow skimmer
 - * overflow rinsing
 - * automatic water filling with chemical dosing
 - * filtration system
 - * basket lifting platform with pneumatic agitation in process
- BATH2 - Rising section with air bubbles:**
 - * heaters 3 kW
 - * level sensor
 - * overflow drain
 - * automatic water filling
 - * air nozzles for air bubbles with pneumatic agitation in process
- BATH3 - Drying section:**
 - * heaters 6 kW
 - * temperature sensor
 - * blowers (circulation)
 - * side and bottom placed compressed air nozzles (rotating by 90°)
 - * basket lifting platform

MATERIALS

- * Working surfaces, baths: polished, AISI 316L (1.4404), Ra-0,8 µm
- * Visible surfaces including working walls and ceiling: brushed, AISI 304 (1.4301), Ra-1,2 µm
- * Non-visible surfaces (internal walls, technical area,...): untreated, AISI 304 (1.4301)

ANMASI	6374-00-00	eX-line 80 WRD AGI
--------	------------	--------------------

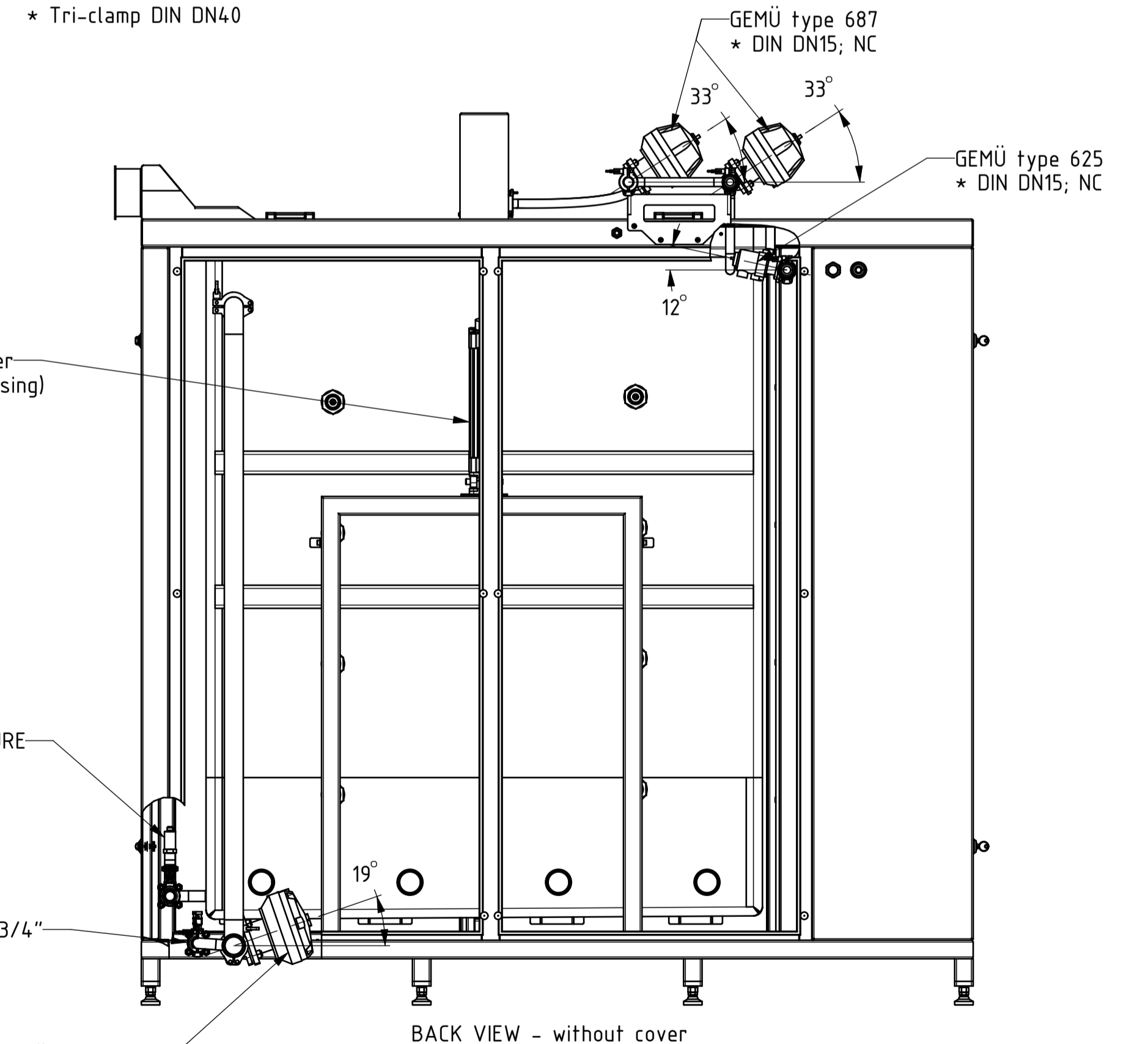
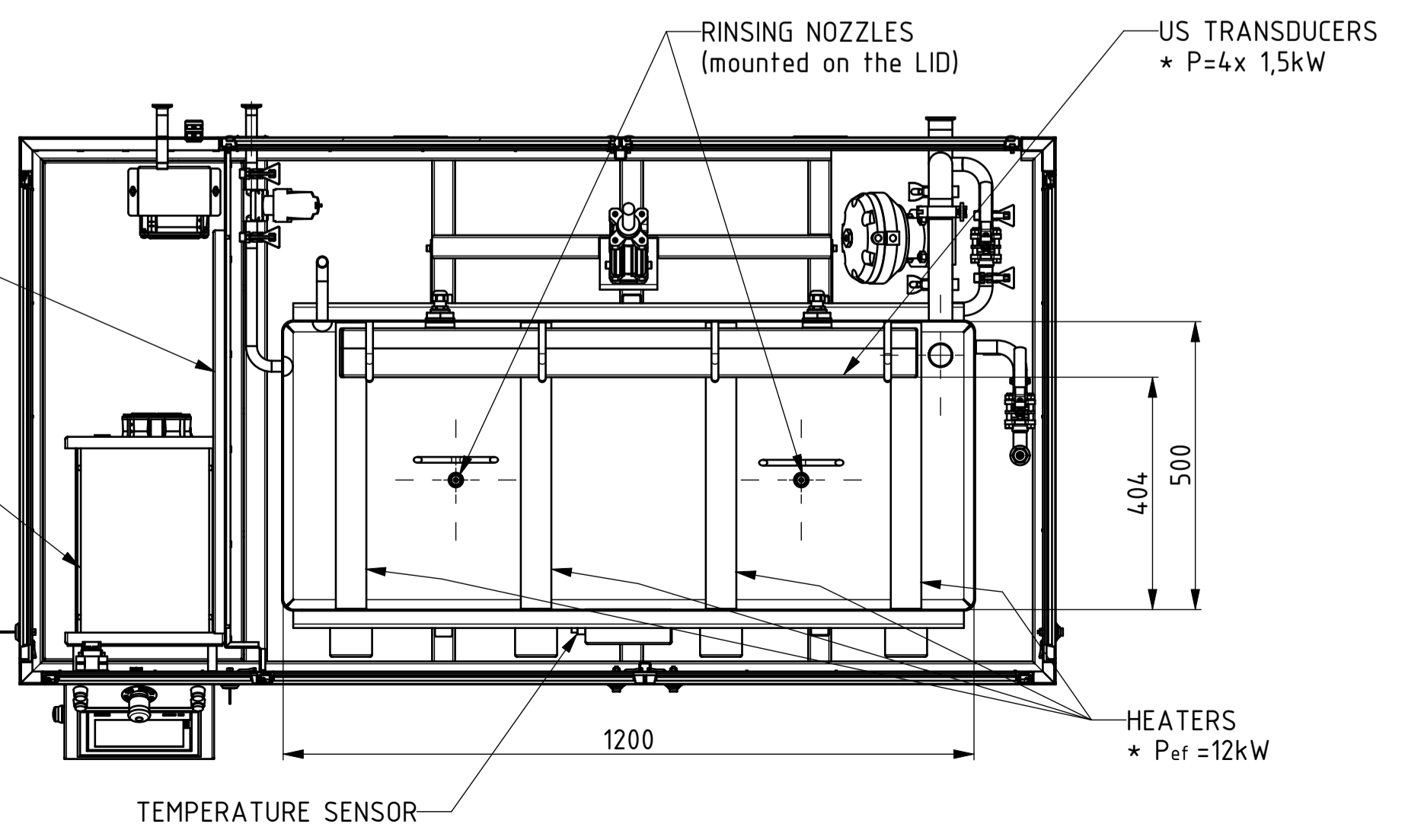
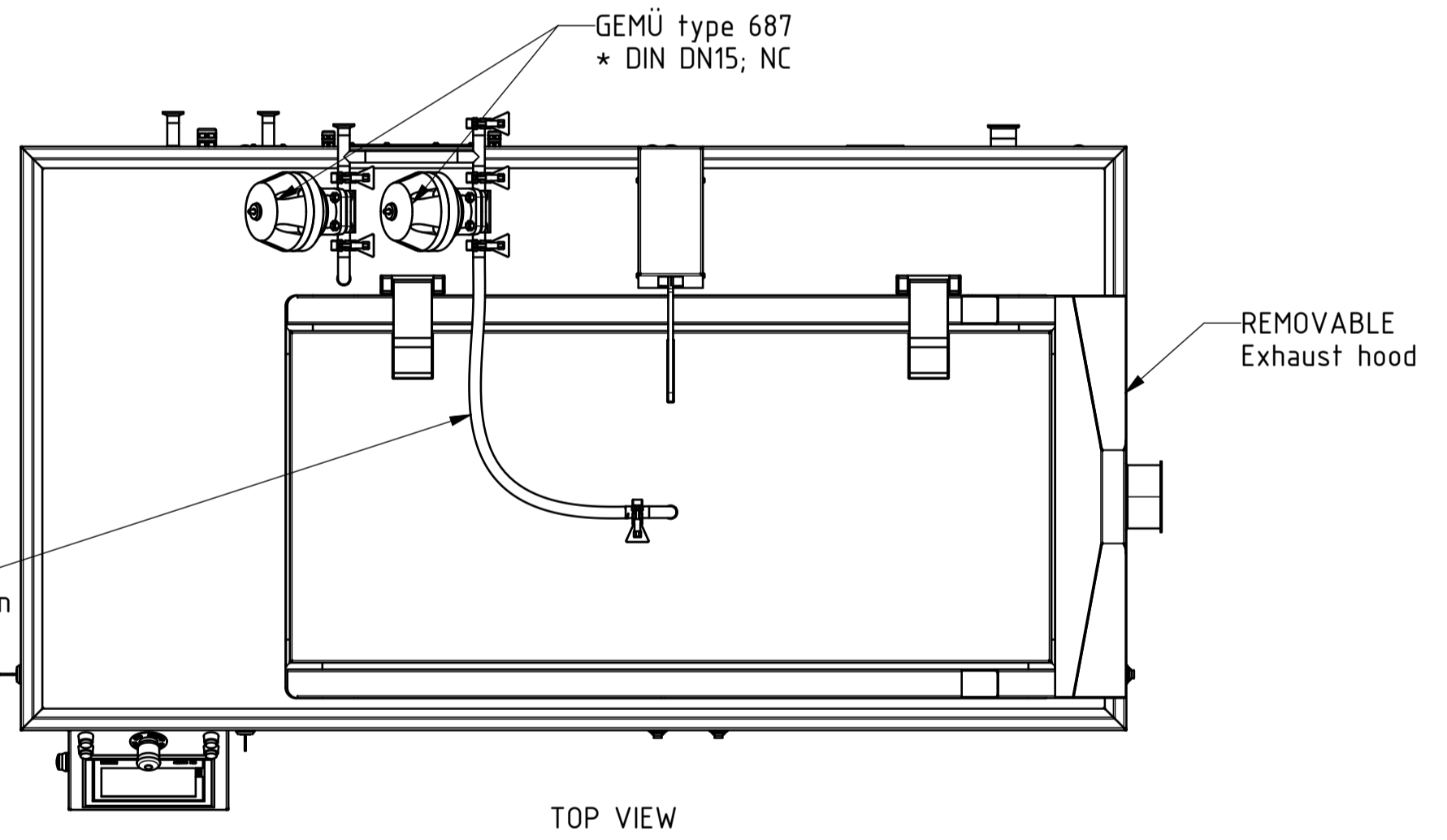
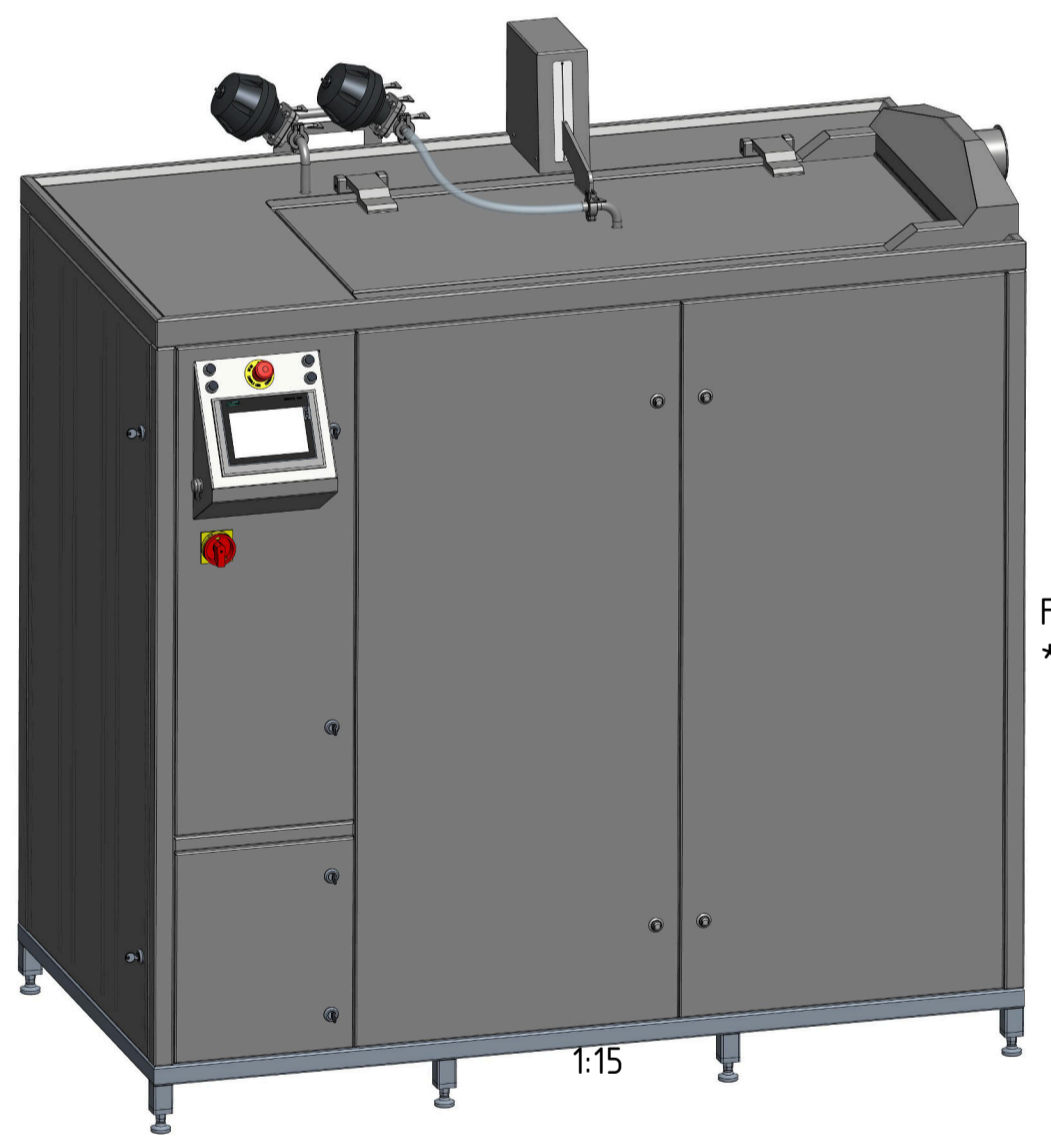
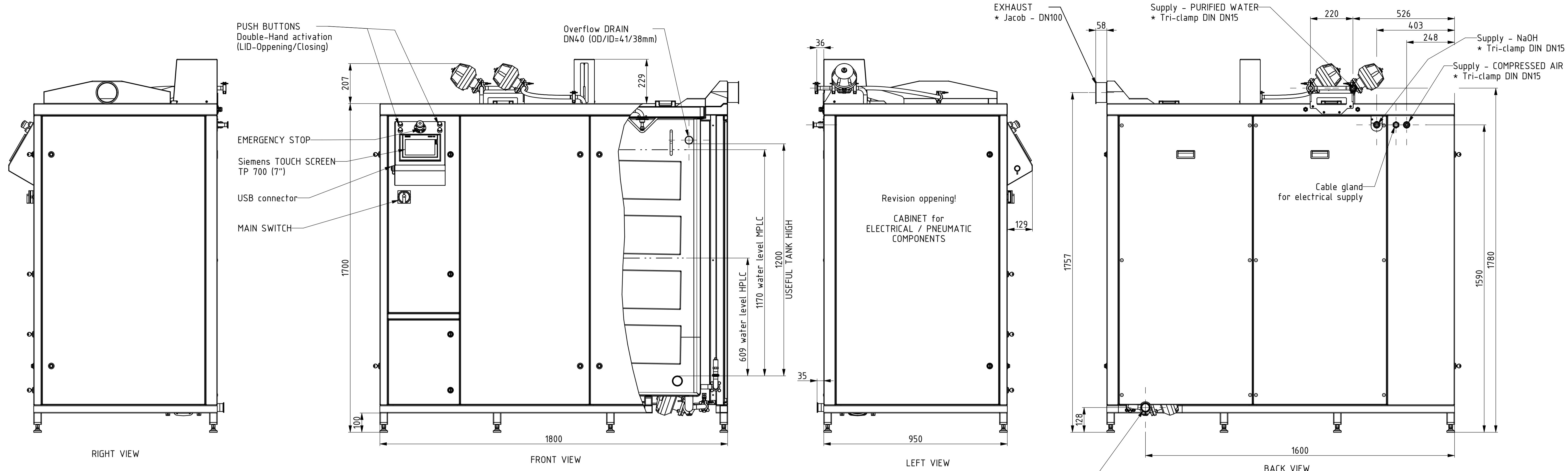

MATERIALS

- * Working surfaces, bath: polished, AISI 316L (1.4404), Ra<0.65µm
- * In contact with media, AISI 316L (1.4404) - in pipes, fittings, Ra<1.0µm; longitudinally welds in pipes Ra<1.6µm
- * Visible surfaces including working walls and ceiling: brushed, AISI 316L (1.4404), Ra<1.6 µm
- * Non-visible surfaces(internal walls, technical area,...): untreated, AISI 304 (1.4301)

Designed:	14.12.2019	Surface Finishing:	Material:	Mass [kg]:	456,224
Approved:	Uroš Juršič				
Heat treat:					
Surface Protection:					
ANMASI		Ultrasonic PHARMALINE 600WR			
Dimensions without tolerance		Model:	Ver. Mod:	Drawing number:	Ver. DRW
Generally: ISO 2768-mS		100384753	A.13	190310_00_220_DRW	A1.00
Any and all information received by you from us shall be held and kept confidential and shall not be disclosed by you to any third party except with prior written consent of Iskra PLO d.o.o.					
		Scale:	1:10	Page: 1/1	